

Taping Specifications for Radial Type of OP-CAP (Applicable Standard JIS C 0806-2)

Fig. 1

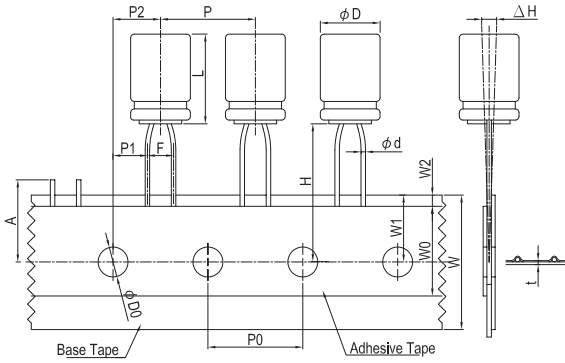
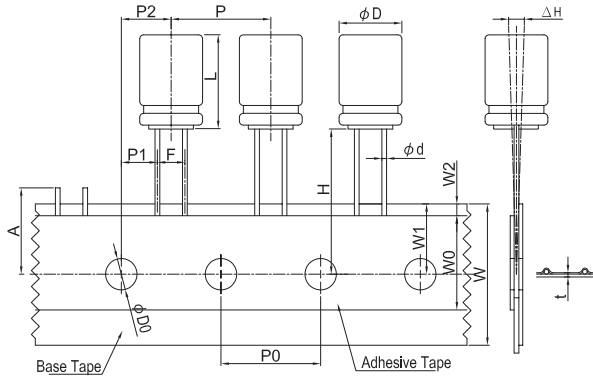

Fig. 2



Unit: mm

Packing	SA								
	ϕD	5		6.3		8		10	Tol.
Symbol	L	8	5.5 ~ 6.5	8	11	6.5 ~ 8	$\geq 11.5^{*1}$	$\geq 10^{*1}$	Tol.
ϕd		0.5	0.45	0.6	0.5	0.6	0.6	0.6	± 0.05
F		2.5	2.5		3.5		3.5	5.0	$+0.8/-0.2$
H		18.5						18.5	± 0.75
P		12.7						12.7	± 1.0
P0		12.7						12.7	± 0.2
P1		5.1	5.1		4.6	4.6		3.85	± 0.7
P2		6.35						6.35	± 1.3
W		18.0						18.0	± 0.5
W0		10.0		12.0	10.0	12.0		12.0	min.
W1		9.0						9.0	± 0.5
W2		1.5						1.5	max.
A		11.0						11.0	max.
$\phi D0$		4.0						4.0	± 0.2
ΔH		0						0	± 1.0
t		0.7						0.7	± 0.2
Fig. No.		1	2					2	---

Note: *1: The tolerance in L for 16 mm is +1.5 mm, for 20 mm is + 2.0 mm.

- If you need parts with pitch is 5.0 mm taping (5 ~ 8 ϕ), please consult with us before placing order.
- Customized taping may be available upon request. Please consult with us.

Package

Fig. 3 Ammo pack box

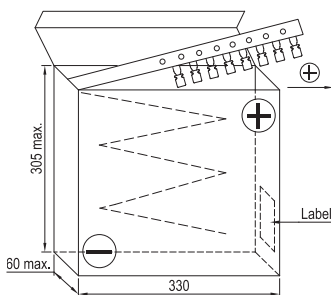

Package Quantity

Unit: pcs / box

ϕD (mm)	5	6.3	8	10
Quantity	2,000	2,000	1,000	500

Note: The component shall be oriented on the tape as such that the positive lead is leading or the negative lead is leading with customer's request.

Lead Cutting Specifications for Radial Type of OP-CAP

Unit: mm

Forming Method	Code	Shape	Dimensions			
Cut (5 ϕ ~ 10 ϕ)	CC		$\phi D \times L$	ϕd	F	H
			5	0.5	2.0	
			6.3 x 5.5 ~ 6.5	0.45	2.5	
			6.3 x 8	0.6		
			6.3 x 11	0.5	3.5	4.5
			8	0.6		
10	0.6	5.0				